

Product: All Makes Common Rail Injector Test

Subject: Application Coverage and Parts

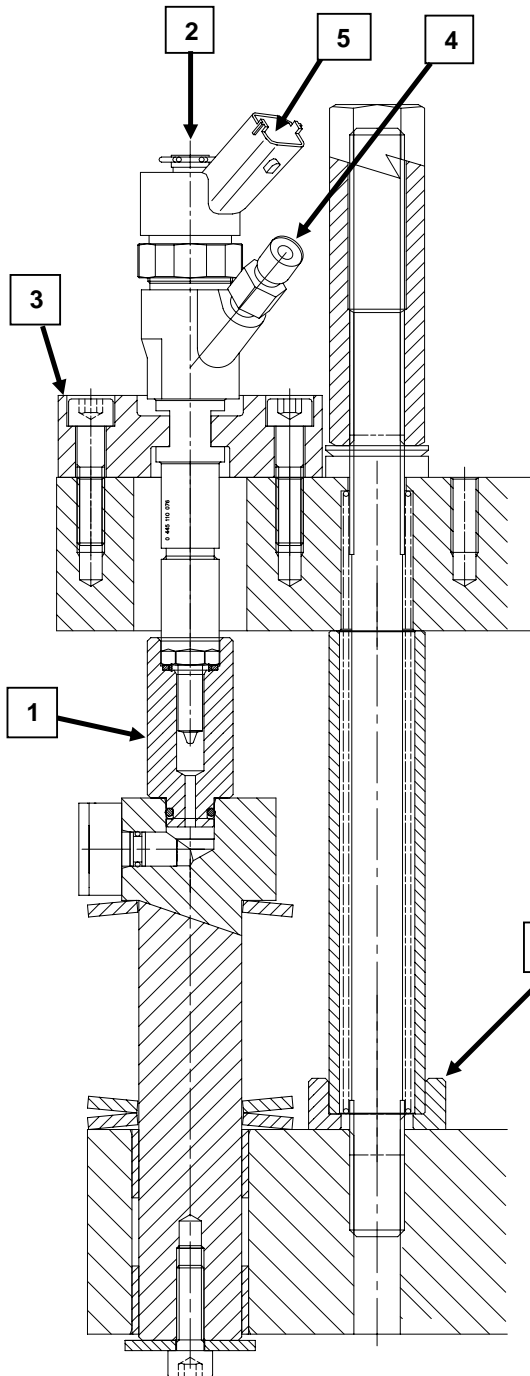

This bulletin details the Common Rail injector types and additional accessories that are required for testing on the AVM2-PC Test Stand using the All Makes Common Rail Injector Test Kit HK900 or the CRi-PC Test Stand.

The drawing shows a typical setup of an injector and its fixturings. The additional accessories that are required for testing are as follows:

1. Nosepiece Adaptor and seals
2. Backleak Adaptor (*not shown*)
3. Clamp Block
4. HP Pipe (rail to injector) (*not shown*)
5. Electrical Cable (*not shown*)
6. Fuelling Sleeve Assembly – Side-ported injectors
7. 9kN Spacer *

*N.B. Item 7 (9kN Spacer NTA5002) is included with the All Makes Common Rail Injector Test Kit HK900 and the CRi-PC Test Stand.

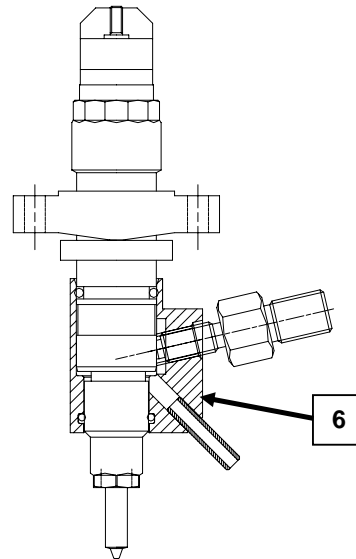

In general the Clamp Block, HP Pipe, and Fuelling Sleeve will be specific to a given part number (or set of part numbers that are dimensionally identical). The other accessories are common to a range of part numbers.

Refer to the application tables overleaf to determine the correct parts for each application.

Bosch Applications

Injector Part Number	Application(s)			Nosepiece Adaptor	Backleak Adaptor	Clamp Block	HP Pipe	Cable Set	Fuelling Sleeve	NTA5002 Required?
	Manuf.	Range	Model	1	2	3	4	5	6	7
0445 110 002 0445 110 068 0445 110 119	Alfa Romeo Fiat Lancia	145, 146 156 166 Bravo / Brava Marea Marengo Multipla Kappa Lybra	1.9 JTD 1.9/2.4 JTD 2.4 JTD 1.9 JTD 1.9 / 2.4 JTD 1.9 JTD 1.9 JTD 2.4 JTD 1.9/2.4 JTD	HK907 (NTA5101)	HK909 (NTA5301)	HK918 (NTA5606)	AHP5129	HK902	N/A	✓
0445 110 009 0445 110 010 0445 110 011 0445 110 012 0445 110 024 0445 110 025 0445 110 034 0445 110 035 0445 110 055 0445 110 069 0445 110 070 0445 110 071 0445 110 072 0445 110 073 0445 110 074 0445 110 094 0445 110 095 0445 110 096 0445 110 099 0445 110 100 0445 110 104 0445 110 105 0445 110 106 0445 110 107 0445 110 108 0445 110 116 0445 110 121 0445 110 129 0445 110 156 0445 110 181 0445 110 182 0445 110 189 0445 110 190 0445 110 206 0445 110 237	Mercedes Benz	Vito Sprinter C Class E Class G Class S Class V Class CLK	2.2 CDI 2.1/2.2/2.7 CDI 200/220/270 CDI 200/220/270 CDI 400 CDI 320/400 CDI 200/220 CDI 270 CDI	HK907 (NTA5101)	HK909 (NTA5301)	HK912 (NTA5601)	AHP5065	HK902	N/A	✓
0445 110 021 0445 110 110 0445 110 146	Renault	Espace Laguna Master Megane Scenic Traffic	1.9 DCI	HK907 (NTA5101)	HK909 (NTA5301)	HK969 (NTA5631)	AHP5065	HK902	N/A	✓
0445 110 028 0445 110 029 0445 110 030 0445 110 047 0445 110 048 0445 110 049 0445 110 130	BMW MG / ROVER	3 Series 5 Series 7 Series X5 75	330d, 330xd 530d 730d, 740d 3.0 d	HK907 (NTA5101)	HK909 (NTA5301)	HK941 (NTA5619)	AHP5065	HK902	N/A	✓
0445 110 036 0445 110 057	Citroen Peugeot	C5 C8 406 607 807	2.2 Hdi 2.2 Hdi 2.2 Hdi 2.2 Hdi 2.2 Hdi	HK907 (NTA5101)	HK909 (NTA5301)	HK937 (NTA5607)	AHP5065	HK902	N/A	✓
0445 110 038 0445 110 063 0445 110 084 0445 110 087 0445 110 102 0445 110 141	Renault Vauxhall / Opel	Avantime Espace Master Movano Vivaro	2.2 DCI 2.2 DCI 2.2 / 2.5 DCI 2.5 DTI	HK907 (NTA5101)	HK909 (NTA5301)	HK971 (NTA5632)	AHP5065	HK902	N/A	✓
0445 110 008 0445 110 044 0445 110 062 0445 110 076	Chevrolet Citroen Peugeot Fiat Lancia	Tracker Berlingo C5 Evasion Jumper Jumpy Xantia Xsara Xsara Picasso 206 306 307 406 607 806 Boxer Expert Partner Scudo Ulysse Z	2.0 D 2.0 Hdi 2.0 Hdi 2.0 Hdi 2.0/2.2 Hdi 2.0 Hdi 2.0 Hdi 2.0 Hdi 2.0 Hdi 2.0 Hdi 2.0 Hdi 2.0 Hdi 2.0 Hdi 2.0/2.2 Hdi 2.0 Hdi 2.0 Hdi 2.0 JTD 2.0 JTD 2.0 JTD	HK907 (NTA5101)	HK909 (NTA5301)	HK914 (NTA5602)	AHP5065	HK902	N/A	✓

Bosch Applications

Injector Part Number	Application(s)			Nosepiece Adaptor	Backleak Adaptor	Clamp Block	HP Pipe	Cable Set	Fuelling Sleeve	NTA5002 Required?
	Manuf.	Range	Model	1	2	3	4	5	6	7
0445 110 059	Chrysler	Voyager	2.5 ltr	HK907 (NTA5101)	HK909 (NTA5301)	HK986 (NTA5641)	AHP5065	HK902	N/A	✓
0445 110 064 0445 110 101 0445 110 126	Hyundai	Accent Elantra Matrix Santa Fe Tussan Trajet	1.5 CRDi 2.0 CRDi 1.5 CRDi 2.0 CRDi 2.0 CRDi 2.0 CRDi	HK907 (NTA5101)	HK909 (NTA5301)	HK939 (NTA5618)	AHP5065	HK902	N/A	✓
	Kia	X-Trax Sportage	2.0 CRDi							
0445 110 075 0445 110 135	Citroen	C3 Xsara	1.4 HDI 1.4 HDI	HK907 (NTA5101)	HK909 (NTA5301)	HK947 (NTA5623)	AHP5129	HK902	N/A	✓
	Peugeot	206 307	1.4 HDI 1.4 HDI							
0445 110 077 0445 110 078	Volvo	S60 S80 V70 XC70 XC90	2.4 D 2.4 D, D5 2.4 D, D5 2.4 D, D5 D5	HK907 (NTA5101)	HK909 (NTA5301)	HK978 (NTA5633)	AHP5065	HK902	N/A	✓
0445 110 083 0445 110 183	Fiat	Albea Doblo Idea Palio Panda Punto Strada	1.3 JTD	HK907 (NTA5101)	HK909 (NTA5301)	HK980 (NTA5634)	AHP5065	HK902	N/A	✓
	Lancia	Musa Ypsilon	1.3 JTD							
	Vauxhall / Opel	Agila Astra Combo Corsa Meriva Tigra	1.3 CDTI							
0445 110 085 0445 110 215	Toyota			HK907 (NTA5101)	HK909 (NTA5301)	HK982 (NTA5636)	AHP5065	HK902	N/A	✓
0445 110 086 0445 110 092 0445 110 185 0445 110 186	Kia	Sorento	2.5 CRDi	HK907 (NTA5101)	HK909 (NTA5301)	HK942 (NTA5620)	AHP5065	HK902	N/A	✓
	Hyundai	Porter	2.5 CRDi							
0445 110 118 0445 110 174	GM / Opel	Astra Combo Corsa Meriva	1.7 CDTI	HK907 (NTA5101)	HK909 (NTA5301)	AVM2-PC: HK943 (NTA5621) CRI-PC: HK1018 (NTA5660)	AHP5129	HK902	N/A	✓
0445 110 080 0445 110 131	BMW	3 Series 3 Series 5 Series 7 Series X5	320 Cd / d / td 330 Cd / d / xd 530 d 730 d 3.0 d	HK907 (NTA5101)	HK909 (NTA5301)	HK988 (NTA5642)	AHP5065	HK902	N/A	✓
0445 110 159	Vauxhall / Opel / SAAB	Astra Signum Vectra Zafira 9-3 9440	1.9 CDTI	HK907 (NTA5101)	HK909 (NTA5301)	HK990 (NTA5643)	AHP5065	HK902	N/A	✓
0445 110 188	Citroen	C4, C5, 1.6HDI, Xsara, Picasso		HK907 (NTA5101)	HK909 (NTA5301)	HK1010 (NTA5658)	AHP5065	HK902	N/A	✓
	Ford	Focus, C Max, Focus 2								
	Peugeot	206, 307, 407								
	Volvo	C30, S40, V50								
0445 110 273	Fiat IVECO	Ducato Daily	2.3 l 2.3 l	HK908 (NTA5102)	HK909 (NTA5301)	HK973 (NTA5638)	AHP5065	HK902	N/A	✓
0445 120 002	Fiat IVECO Renault	Ducato Daily Mascott	2.8 JTD 2.8 litre 2.8 litre	HK908 (NTA5102)	HK909 (NTA5301)	HK922 (NTA5605)	AHP5065	HK902	N/A	✓
0445 120 003 0445 120 004 0445 120 019 0445 120 020	Renault	Premium Kerax	11.1 litre	HK921 (NTA5103)	N/A	HK934 (NTA5617)	AHP5130	HK903	HK936 (NTA5402, NTA5501)	✓
0445 120 007 0445 120 018 0445 120 028	Cummins applications			HK907 (NTA5101)	N/A	HK926 (NTA5603)	AHP5130	HK903	HK928 (NTA5401, NTA5501)	✓
0445 120 008	GM Chevrolet	Sierra Silverado	Duramax 2500HD Duramax 3500 Duramax 2500HD Duramax 3500	HK921 (NTA5103)	HK910 (NTA5302)	HK924 (NTA5604)	AHP5066	HK903	N/A	✓
0445 120 011	Fiat IVECO	Ducato 11/15/18 Daily 29/35	2.3 JTD 2.3 ltr	HK908 (NTA5102)	HK909 (NTA5301)	HK973 (NTA5638)	AHP5065	HK902	N/A	✓
0445 120 012 0445 120 013	Renault	Midlum Premium	4.0, 6.2 ltr 6.2 ltr	HK998 (NTA5105)	N/A	HK975 (NTA5639) + HK976 (NTA5640)	AHP5066	HK903	N/A	✓

Bosch Applications

0445 120 030	MAN	TGA D2066LF	7.5 ltr	HK907 (NTA5101)	N/A	HK991 (NTA5648)	AHP5130	HK903	HK992 (NTA5405, NTA5501)	✓
0445 120 041	MAN			HK907 (NTA5101)	N/A	HK1052 (NTA5678)	AHP5130	HK903	HK992 (NTA5405, NTA5501)	✓
0445 120 045 0445 120 098	MAN	TGA D0836LF TGAL D0834LF TGAM 0836LF	12 ltr, 4.6 ltr, 6.9 ltr	HK907 (NTA5101)	N/A	HK1012 (NTA5654)	AHP5130	HK903	HK1013 (NTA5406, NTA5501)	✓
0445 120 050 0445 120 059 0445 120 071 0445 120 161 0445 120 184 0445 120 185	Cummins applications			HK907 (NTA5101)	N/A	HK1014 (NTA5661)	AHP5130	HK903	HK928 (NTA5401)	✓
0445 120 006	MAN			HK921 (NTA5103)	N/A	HK1019 (NTA5664)	AHP5130	HK903	HK1020 (NTA5408)	✓
0445 120 044	MAN		TGA 18.480 – 12.8 L TGA18530F – 12.8 L TGA24.480 – 12.8 L TGA 56.530 – 12.8 L	HK907 (NTA5101)	N/A	HK1012 (NTA5654)	AHP5130	HK903	HK1016 (NTA5407, NTA5501)	✓
0445 120 032	Cummins		5.9 ltr	HK907 (NTA5101)	HK909 (NTA5301)	HK1024 (NTA5668)	AHP5066	HK902	N/A	✓
0445 120 065 0445 120 066 0445 120 067	Deutz	04290986 04290987	KHD0429 0986 HKD0429 0987 TCD4120122V (US)	HK907 (NTA5101)	HK1047 (NTA5412)	HK1046 (NTA5674)	AHP5066	HK903	N/A	✓
0445 120 064 0445 120 136 0445 120 137	Deutz Renault Volvo	KDH04290 2825 Midlum, Premium	4.8, 7.2 ltr	HK907 (NTA5101)	N/A	HK1044 (NTA5675)	AHP5066	HK903	HK1045 (NTA5413, NTA5501)	✓
0445 120 029 0445 120 125	Komatsu			HK907 (NTA5101)	N/A	HK1040 (NTA5672)	AHP5130	HK903	HK1041 (NTA5410, NTA5505)	✓
0445 120 035 0445 120 125 0445 120 112	Cummins	4940439 4940170								

Delphi Applications

Injector Part Number	Application(s)			Nosepiece Adaptor	Backleak Adaptor	Clamp Block	HP Pipe	Cable Set	Fuelling Sleeve	NTA5002 Required?	
	Manuf.	Range	Model	1	2	3	4	5	6	7	
EJBR01001A EJBR01001Z	Suzuki Citroen	Liana C3	1.4 Ddis 1.4 HDI	HK907 (NTA5101)	HK911 (NTA5303)	HK916 (NTA5610) + HK933 (NTA5614)	Official Solution requires HK917 (1/4: AHP5009 2/3: AHP5010) OR All Makes AHP5066	HK904	N/A	✓	
EJBR00801Z EJBR01101Z EJBR01301Z EJBR01302Z EJBR01601Z EJBR02001Z EJBR02201Z	Ford	Focus Transit Connect Tourneo Connect	1.8 TDCi 1.8 TDCi 1.8 TDCi	HK907 (NTA5101)	N/A	HK916 (NTA5610) + HK930 (NTA5611)		HK904	N/A	✓	
EJBR01201Z EJBR01401Z EJBR01501Z EJBR01701Z EJBR01801A EJBR01801Z EJBR02101Z EJBR02701Z EJBR03101D EJBR04001D EJBR04101D EJBR05101D EJBR05102D EJBR05201D EJBR05601D	Renault Nissan Suzuki	Clio Kangoo Megane Scenic Modus Almera Kubistar Micra Jimny	1.5 dCi 1.5 dCi 1.5 dCi 1.5 dCi 1.5 dCi 1.5 dCi 1.5 dCi 1.5 dCi 1.5 Ddis	HK907 (NTA5101)	N/A	HK916 (NTA5610)		HK904	N/A	✓	
EJBR05301D EJBR06101D	Yuchai		2.5 ltr 2.6 ltr								
EJBR00901Z EJBR01901Z EJBR02301Z EJBR02401Z EJBR02501Z EJBR02801D EJBR02901D EJBR03001D EJBR03201D EJBR03601D EJBR03701D	Kia	Carnival Pregio Bongo Frontier	2.9 HPDi 2.9 HPDi 2.9 HPDi 2.9 HPDi	HK907 (NTA5101)	N/A	HK916 (NTA5610) + HK931 (NTA5612)		HK904	N/A	✓	
EJBR03901D EJBR03902D EJBR05501D	Hyundai Kia		2.9								
EJBR03301D EJBR03501D	JMC TATA		2.8 3.0								
EJBR02601Z EJBR03401Z EJBR04601Z EJBR04701Z	Ssangyong	Rodius Rexton	D27DT D20DT D27DT D20DT	HK907 (NTA5101)	N/A	HK916 (NTA5610) + HK932 (NTA5613)		HK904	N/A	✓	
EJBR04301D EJBR04901D EJBR05701D	TATA		1.4L 2.2L								
EJBR04401Z EJBR04501Z EJBR04401D EJBR04501D	Ssangyong										
EJBR03801D EJBR06001D	PSA			HK907 (NTA5101)	HK911 (NTA5303)	HK1001 (NTA5650)		HK904	N/A	✓	
EJBR04201D	Daimler Chrysler			HK907 (NTA5101)	HK911 (NTA5303)	HK916 (NTA5610) + HK1004 (NTA5651)		HK904	N/A	✓	
EJBR05001D	JCB		4.4L	HK907 (NTA5101)	HK911 (NTA5303)	HK987 (NTA5644)		HK904	N/A	✓	
EJBR06201D				HK907 (NTA5101)	HK911 (NTA5303)	HK916 (NTA5610) + HK1005 (NTA5655)		HK904	N/A	✓	
EJDR00001Z EJDR00002Z EJDR00101Z EJDR00201Z EJDR00202Z EJDR00301Z EJDR00401Z EJDR00402Z EJDR00403Z EJDR01001D EJDR01101D	Ford	Mondeo Transit	2.0 TDCi 2.0 TDCi	HK907 (NTA5101)	HK911 (NTA5303)	HK920 (NTA5608)		HK904	N/A	✗	

Delphi Applications

EJDR00501Z	Ford	Mondeo	2.0 TDCi							
EJDR00502Z										
EJDR00503Z										
EJDR00504Z	Jaguar	X400	2.0 TDCi	HK907 (NTA5101)	HK911 (NTA5303)	HK920 (NTA5608) + HK929 (NTA5609)		HK904	N/A	x
EJDR00601Z										
EJDR00701D										
EJDR00801D										

Denso Applications

Injector Part Number	Application(s)			Nosepiece Adaptor	Backleak Adaptor	Clamp Block	HP Pipe	Cable Set	Fuelling Sleeve	NTA5002 Required?
	VM	VM Inj Ref	Model	1	2	3	4	5	6	7
095000-014x	Isuzu		6HK1	HK921 (NTA5103)	HK1007 (NTA5305)	HK1008 (NTA5656)	AHP5066	HK963	N/A	✓
095000-057x	Toyota	23670-27030	Avensis Avensis Verso Previa RAV4	HK907 (NTA5101)	HK910 (NTA5302)	HK997 (NTA5637) + HK956 (NTA5626) + HK932 (NTA5613)	AHP5065	HK905	N/A	✓
095000-064x	Toyota	23670-29025	Corolla							
095000-075x	Toyota	23670-39025	Land Cruiser							
095000-094x	Toyota	23670-39035	4Runner Dyna Hiace Hilux Tiger 2.5l							
095000-542x	Toyota	23670-09030	Avensis Avensis Verso Corolla Corolla Verso							
095000-558x	Toyota	23670-29045	Avensis Corolla							
095000-589x	Toyota	23670-39135	Land Cruiser							
095000-593x	Toyota	23670-09060 23670-0L010	Hilux Vigo 2.5l							
095000-074x	Toyota	23670-39015	Land Cruiser							
095000-095x	Toyota	23670-39045	Dyna	HK907 (NTA5101)	HK910 (NTA5302)	HK997 (NTA5637) + HK956 (NTA5626) + HK932 (NTA5613)	AHP5065	HK959	N/A	✓
095000-611x	Toyota	23670-09130	Avensis	HK907 (NTA5101)	HK910 (NTA5302)	HK997 (NTA5637) + HK956 (NTA5626) + HK957 (NTA5627)	AHP5065	HK905	N/A	✓
095000-623x	Toyota	23670-09140	Corolla Verso RAV4							
095000-051x 095000-088x 095000-513x 095000-518x 095000-565x 095000-602x 095000-624x 095000-625x	Nissan	16600-8H80x 16600-AU600 16600-AW40x 16600-BN80x 16600-EB30x 16600-ES60x 16600-MB40x 16600-EC00x	Almeria Cabstar Pathfinder Primera Navara X-Trail	HK907 (NTA5101)	HK910 (NTA5302)	HK996 (NTA5646)	AHP5065	HK905	N/A	✓
095000-560x	Mitsubishi	1465*041	L200	HK907 (NTA5101)	HK910 (NTA5302)	HK997 (NTA5637) + HK956 (NTA5626) + HK932 (NTA5613)	AHP5065	HK905	N/A	✓
095000-576x	Mitsubishi	1465A054	Pajero Montero	HK907 (NTA5101)	HK910 (NTA5302)	HK997 (NTA5637) + HK956 (NTA5626) + HK1000 (NTA5649)	AHP5065	HK905	N/A	✓
095000-056x	Komatsu	62181-13100 62181-13101		HK921 (NTA5103)	HK962 (NTA5403)	HK964 (NTA5629)	AHP5130	HK963	N/A	✓
095000-076x	Isuzu	10F0225	6SD1	HK907 (NTA5101)	HK1007 (NTA5305)	HK1061 (NTA5686)	AHP5066	HK905	N/A	✓
095000-080x	Komatsu	61561-13100		HK921 (NTA5103)	HK962 (NTA5403)	HK960 (NTA5628)	AHP5066	HK963	N/A	✓
095000-121x	Perkins	05H0217		HK984 (NTA5104)	HK962 (NTA5403)	HK1055 (NTA5680)	AHP5066	HK963	N/A	✓
095000-505x 095000-548x	John Deere	RE507860 RE520240	Tractor (6045 engine)	HK907 (NTA5101)	N/A	HK966 (NTA5630)	AHP5130	HK963	HK968 (NTA5404, NTA5502)	✓
095000-512x	Toyota	23670-0G010	Avensis Corolla RAV4	HK907 (NTA5101)	HK910 (NTA5302)	HK1062 (NTA5687)	AHP5065	HK905	N/A	✓
095000-630x	Perkins			HK984 (NTA5104)	HK1007 (NTA5305)	HK1056 (NTA5681)	AHP5130	HK963	N/A	✓
095000-670x 095000-801x				HK984 (NTA5104)	HK1007 (NTA5305)	HK1008 (NTA5656) + HK1057 (NTA5682)	AHP5066	HK963	N/A	✓
095000-698x 095000-699x	Isuzu	98011604 98011605	2.5 ltr 3.0 ltr	HK907 (NTA5101)	HK1006 (NTA5307)	HK1002 (NTA5652) + HK1003 (NTA5653)	AHP5066	HK905	N/A	✓
095000-508x	Vauxhall / Opel	97313861	Corsa Combo Meriva	HK907 (NTA5101)	HK1006 (NTA5307)	AVM2-PC: HK943 (NTA5621) CRI-PC: HK1018 (NTA5660)	AHP5129	HK905	N/A	✓
095000-547x	Isuzu (Opel)		Corsa Combo Meriva	HK921 ^[1] (NTA5103)	HK1007 (NTA5305)	HK1008 (NTA5656)	AHP5130	HK963	N/A	✓

Denso Applications

095000-580x 095000-581x 095000-662x 095000-706x	Citroen Fiat Ford Land Rover Peugeot	6C1Q-9K546-AC 6C1Q-9K546-BB 6C1Q-9K546-BC	Jumper 2.2ltr Ducato 2.2ltr Transit 2.2, 2.4ltr Defender 2.4ltr Boxer 2.2, 2.4ltr	HK907 (NTA5101)	HK1006 (NTA5307)	HK997 (NTA5637) + HK956 (NTA5626) + HK1009 (NTA5657)	AHP5065	HK905	N/A	✓
095000-578x	Mazda	RF7J13H50	3, 5, 6	HK907 (NTA5101)	HK910 (NTA5302)	HK997 (NTA5637) + HK956 (NTA5626) + HK1011 (NTA5659)	AHP5130	HK905	N/A	✓
095000-539x 095000-599x 095000-635x 095000-692x	Hino Nissan Toyota			HK984 (NTA5104)	HK910 (NTA5302)	HK993 (NTA5645)	AHP5066	HK963	N/A	✓
095000-528x 095000-659x 095000-681x 095000-809x	Hino Nissan Toyota			HK984 (NTA5104)	HK994 (NTA5304)	HK993 (NTA5645)	AHP5066	HK963	N/A	✓
095000 503x	Mazda		MPV 6	HK907 (NTA5101)	HK1006 (NTA5307)	HK1023 (NTA5666, NTA5667)	AHP5130	HK905	N/A	✓

^[1] Only kits/parts purchased after March 09 will fit (design change to suit this application).

NOTE: HP Pipes for Denso Official Solution TBA.

CAT / Perkins Applications

Injector Part Number	Application(s)			Nosepiece Adaptor	Backleak Adaptor	Clamp Block	HP Pipe	Cable Set	Fuelling Sleeve	NTA5002 Required?
	VM	VM Inj Ref	Model	1	2	3	4	5	6	7
2S0012401325/ 2645A718	Perkins			HK907 (NTA5101)	N/A	HK1042 (NTA5673)	AHP5066	HK963	HK1043 (NTA5411)	✓
2S00491407FB / 2645A749			100VK, NH1, NJ1, 1104D engine, John Deere 4.4ltr							

VDO (Siemens) Applications

Injector Part Number	Application(s)			Nosepiece Adaptor	Backleak Adaptor	Clamp Block	HP Pipe	Cable Set	Fuelling Sleeve	NTA5002 Required?	
	VM	VM Inj Ref	Model	1	2	3	4	5	6	7	
5WS40000-Z	PSA	1980 F0 96 521 736 80	DW10TD 2.0ltr	HK907 (NTA5101)	HK909 (NTA5301)	HK945 (NTA5622)	AHP5065	HK906	N/A	✓	
5WS40148-Z	Ford	2S6Q-9F593-AB 2S6Q-9F593-AC	1.4 Litre Euro 3	HK907 (NTA5101)	HK909 (NTA5301)	HK947 (NTA5623)	AHP5065	HK906	N/A	✓	
	PSA	96 553 048 80 1980 E7									
5WS40149-Z	Ford	2S6Q-9F593-BC	1.4 Litre Euro 4	HK907 (NTA5101)	HK909 (NTA5301)	HK949 (NTA5624)	AHP5065	HK906	N/A	✓	
	PSA	96 545 509 80 1980 J1									
5WS40156-4Z	Ford	3M5Q 9F593 DB	DW10B Class 4	HK907 (NTA5101)	HK909 (NTA5301)	HK949 (NTA5624)	AHP5065	HK906	N/A	✓	
	PSA	1980 J5 96 571 445 80									
	Volvo	8603565									
5WS40156-Z	Ford	3M5Q 9F593 EB	DW10B Class 5	HK907 (NTA5101)	HK909 (NTA5301)	HK949 (NTA5624)	AHP5065	HK906	N/A	✓	
	PSA	1980 J5 96 571 447 80									
	Volvo	8603564									
5WS40057 (A2C59511315)	Ford Jaguar PSA	Lion V6	2.7i Litre Euro 3/4	HK907 (NTA5101)	HK909 (NTA5301)	HK989 (NTA5635)	AHP5065	HK906	N/A	✓	
5WS40103 (A2C59511316)	Ford	5U3Q 9K546 AA		HK907 (NTA5101)	HK909 (NTA5301)	HK989 (NTA5635)	AHP5065	HK906	N/A	✓	
	Jaguar	C2S 40004									
	PSA	1980.H1 96 489 170 80									
5WS40249 (A2C59511364)	Ford	4H2Q 9K546 AF		HK907 (NTA5101)	HK909 (NTA5301)	HK989 (NTA5635)	AHP5065	HK906	N/A	✓	
	Land Rover	LR006495									
5WS40156-6 (A2C59511601)	Ford	1483820 3M5Q 9F593 FB		HK907 (NTA5101)	HK909 (NTA5301)	HK949 (NTA5624)	AHP5065	HK906	N/A	✓	
	Volvo	312 16 456									
5WS40200 (A2C59511602)	PSA	1980.K5		HK907 (NTA5101)	HK909 (NTA5301)	HK949 (NTA5624)	AHP5065	HK906	N/A	✓	
5WS40441 (A2C59511603)	PSA	1980.K8 96 603 348 80		HK907 (NTA5101)	HK909 (NTA5301)	HK949 (NTA5624)	AHP5065	HK906	N/A	✓	
5WS40516 (A2C59511612)	PSA	1980.L0 96 634 292 80		HK907 (NTA5101)	HK909 (NTA5301)	HK947 (NTA5623)	AHP5065	HK906	N/A	✓	
5WS40539	VW	03L 130 277 B		HK907 (NTA5101)	HK909 (NTA5301)	HK1054 (NTA5679) HK1011 (NTA5659)	AHP5129	HK906	N/A	✓	
5WS40086 (A2C59511610) 5WS40250 (A2C59511611)	Ford	1355051 1432322	Lynx 1.8 85 to 93kW	HK907 (NTA5101)	HK909 (NTA5301)	HK1025 (NTA5669)	AHP5065	HK906	N/A	✓	
5WS40087 (A2C59511606)	Renault Nissan	8200 842 205 8200 380 253	Clio, Modus, Scenic, Megane Quashqai, Tiida	HK907 (NTA5101)	HK909 (NTA5301)	HK1048 (NTA5677)	AHP5065	HK906	N/A	✓	
1875072C91	Ford		Powerstroke 6.4l	AVM2 & CRI	HK1053 (NTA5107)	HK1017 (NTA5663)	HK1015 (NTA5662)	AHP5130	HK1026	N/A	✓
				IFT- 70	N/A	HK1017/C (NTA5663)	N/A	N/A	HK845	N/A	N/A

Notes on Application Tables

The kit numbers HK9xx contain parts for four injectors. For the single-line CRi-PC, the same kit numbers can be used but with the addition of the suffix "/C" e.g. HK9xx/C. These "/C" kits will contain appropriate parts for a single injector. For the IFR-50, the same cable kit numbers can be used but with the addition of the suffix "/R" e.g. HK9xx/R. These "/R" kits will contain shorter versions of the standard cables suitable for IFR-50 use.

Nosepiece adaptors and clamp blocks are not required for IFR-50. Where NTA5xxx numbers are shown in brackets under the HK9xx number; these identify the major part number in the kit. This is for reference only as the kit will contain other small items e.g. o rings, washers, bolts that will be required.

N/A = not applicable TBA = kit to be announced.

Highlighted text shows applications added since last issue.

Flexible High Pressure Pipes

The references below are flexible high pressure pipes for All Makes CRi test solutions. These are sold as single items; one pipe per injector line:

AHP5065	HP Flexible Pipe – 400x14x12
AHP5066	HP Flexible Pipe – 400x14x14
AHP5129	HP Flexible Pipe – 350x14x12, 90° Elbow
AHP5130	HP Flexible Pipe – 400x14x14, 90° Elbow

For IFR-50 use, the all makes flexible high pressure pipes should be used.

Recommended HP Pipe (solid) fitment, i.e. HK917

1. The threaded collar end of the pipe should be fitted to the rail port.
2. Offer this end up to the rail and adjust the position of the collar as necessary: a gap of approx 1 mm should be left between the rail seat and the HP collar to ensure that the pipe seals on the cone face (and not on the collar itself).
3. Hand tighten nut to position the pipe and then torque to 35 kN.

For Leak Test Adaptors, HK952 Delphi, HK953 & HK954 Bosch see TB195/16.

Additional applications are under development; please contact Hartridge™ for the latest information and coverage.